

BEE3 Expansion Modules

Analog-to-Digital Converters

Radar Signal Processing

Synthetic aperture radar signal synthesis and processing with full multi-GHz analog bandwidth and the digital process power to every Hertz of the spectrum

Cognitive Radio and Wireless Communications

Ultra-wide-band wireless communications implementation with multi-GHz A/D and D/A interfaces

High Performance DSP

Create complex digital signal processing applications with tera operations per second throughput

Contact Info:

+1 (510) 252-1136
 sales@beecube.com
 www.beecube.com

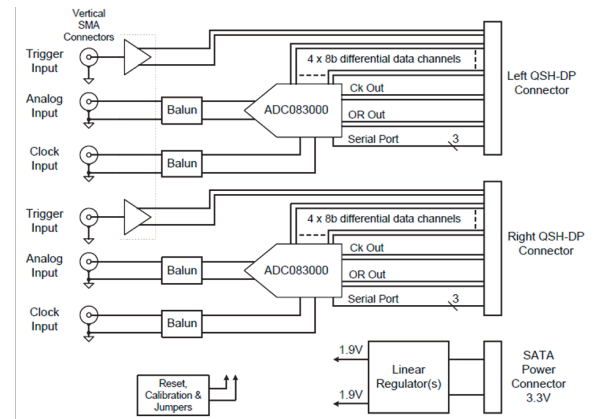
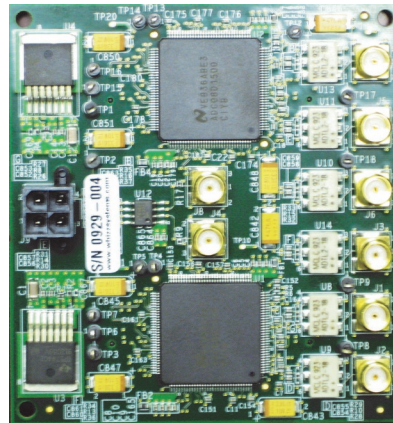

3GHz 8-bit Dual Channel ADC

- National Instruments ADC083000
- 2 independent or I/Q Analog Inputs
- Up to 3 Gbps sample rate
- Full 3GHz analog bandwidth
- 8-bit digital outputs 4-to-1 demuxed
- 7.0 bits ENOB @ 748MHz input(typ.)
- 44.5 dB SNR @ 748MHz input(typ.)
- Trigger inputs for signal synchronization

1.5GHz 8-bit Quad Channel ADC

- National Instruments ADC08D1500/1520
- 4 independent or I/Q Analog Inputs
- Up to 1.5 Gbps sample rate
- 8-bit digital outputs 4-to-1 demuxed
- 7.25 bits ENOB @ 748MHz input(typ.)
- Trigger inputs for signal synchronization

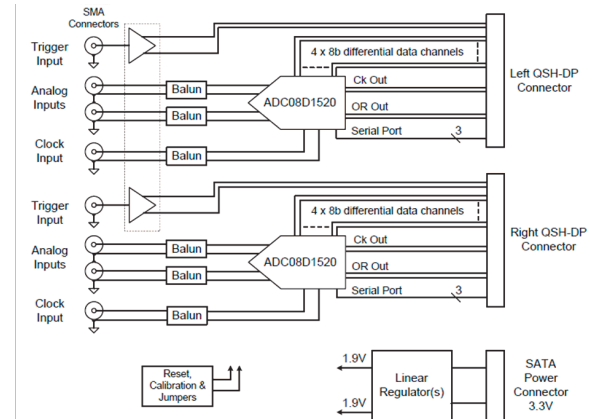

BEE3 Expansion Modules

Digital-to-Analog Converters

Radar Signal Processing

Synthetic aperture radar signal synthesis and processing with full multi-GHz analog bandwidth and the digital process power to every Hertz of the spectrum

Cognitive Radio and Wireless Communications

Ultra-wide-band wireless communications implementation with multi-GHz A/D and D/A interfaces

High Performance DSP

Create complex digital signal processing applications with tera operations per second throughput

Contact Info:

+1 (510) 252-1136
 sales@beecube.com
 www.beecube.com

2GHz 9-12bit Dual Channel DAC

- Teledyne RDA112M4MSPLD
- 2 independent or I/Q Analog outputs
- Full 2GHz output bandwidth
- Selectable Resolution vs. Sample rates:
- 12 bits resolution from 0.001 to 1.5Gsp/s
- 9 bits resolution up to 2Gsp/s
- 4-to-1 or 2-to-1 muxed digital inputs
- Master/Slave mode for phase matched I/Q outputs

