



**SoC and ASIC RTL Prototyping**

Real-world, real-time, cycle accurate prototyping and functional verification and validation of RTL based chipsets, including multi-core SoC's and software bring up

**Networking Prototyping and I/O Performance Testing**

Verification and prototyping of real packet data at real loads of networking chipsets, including PHYs, at Gbps+ interface speeds

**Multi-core SoC Design**

Real-time prototyping of large scale next generation multi-core System-on-Chip designs with ease

**HD Video Processing**

High definition video processing with multiple real-time 1080p video data streams

**Cognitive Radio and Wireless Communications**

Ultra-wide-band wireless communications implementation with multi-GHz A/D and D/A interfaces

**High Performance DSP**

Create complex digital signal processing applications with tera operations per second throughput

**Contact Info:**

+1 (510) 252-1136  
 sales@beecube.com  
 www.beecube.com

# BEE3 Hardware Platform

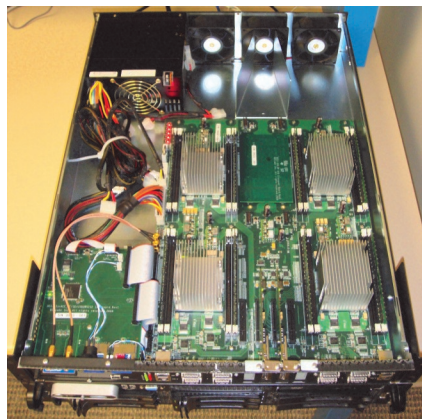

BEE3 is perfectly suited as a real-time, real-world prototyping and development platform. BEE3 is a true high-speed multiple FPGA and validation solution.

BEE3 is designed to target:

- New SoC and multi-core CPU architecture exploration and validation
- High-speed SoC or IP ASIC RTL and gate level prototyping and verification
- High-speed computation and algorithm prototyping

Evolved from the original Berkeley Emulation Engine (BEE), BEE3 is the third generation commercial FPGA based computer system. Jointly developed by Microsoft Research, UC Berkeley, and BEEcube Inc., the BEE3 system design draws from lessons learned in previous generations and from over 40 years of design experience of the legendary computer architect and 2009's Turing Award winner, Chuck Thacker, BEE3's chief designer. Over 150 BEE systems have been deployed worldwide.

Using the state-of-art Xilinx 65nm FPGA family, each 2U rack mount BEE3 module consists of four large Virtex-5 LXT/SXT/FXT FPGA chips, along with up to 64GB

DDR2 ECC DRAM and eight 10GigE interfaces for inter-module communication. In addition, up to 4 PCI Express x8 connections allow a maximum of 16GB per second, full-duplex data communication between each BEE3 module and computer host servers. At a power consumption of less than 400 watts, each BEE3 module can provide over 4 trillion integer operations per second, or emulate over 64 RISC processor cores concurrently at a 100 MHz rate.

BEE3 systems have been used for various applications, verification/validation and research. BEE3 customers include leading companies like Xilinx, Microsoft, Sun Microsystems, Aerospace, Thales and L3 Communications. Leading universities deploying BEE3 technology include University of California Berkeley, Stanford University, Massachusetts Institute of Technology, Imperial College London, Barcelona Super Computer Center, Tokyo University, Cambridge University, and Peking University.



Please e-mail sales@beecube.com for additional information.

### Turnkey Solution

Everything a designer needs to successfully create a compelling application, from hardware to software, interface IPs to operating systems

### Technical Support

Experienced technical support staff is available for immediate response within 1 business day via email or telephone

### Design Services

Accelerate your next project development with our dedicated services from application domain experts

### Endless Solutions

Go beyond the basics to next level of integration with our expanding collection of expansion modules, specially designed to meet your application needs

### Contact Info:

+1 (510) 252-1136  
 sales@beecube.com  
 www.beecube.com

## BEE3 Key Features

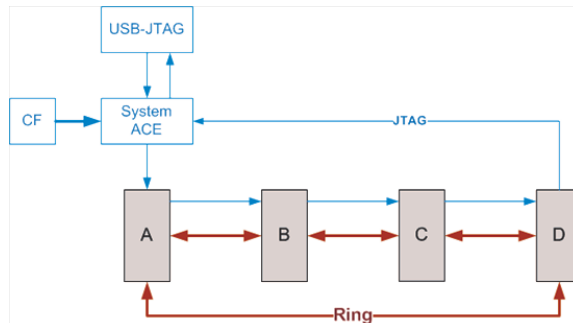
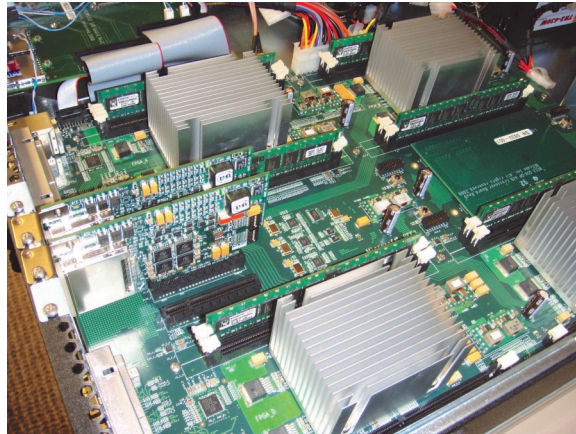

### State-of-art Xilinx Virtex-5 FPGAs

- Four LX155T/SX95T FPGAs on a ring
- Over 400MHz clock rate
- 5M gate capacity
- 2560 DSP slices

### Scalable Cluster Solution

- Scale from a single module to 1024 modules
- 16~20 modules per rack
- Less than 5KWatt power consumption per rack
- Over 1TB DRAM per rack

### Flexible System Integration

- Multiple host computer interfaces via USB, Ethernet, and PCI Express
- Remote system administration via USB or Ethernet
- Support for both Windows and Linux computer systems
- Direct integration with MATLAB and native C API for custom applications

### Each FPGA provides:

- Dual channel DDR2-400/533/667 RDIMMs, two DIMMs per channel
- Maximum of 4GB DRAM capacity per DIMM, 16GB total per FPGA
- Dual 10GBase-CX4 Ethernet interface
- A single PCI-Express x8 end-point slot
- 40 pairs direct LVDS high-speed connection to external multi-GHz analog converter devices, such as ADC and DAC
- Tri-mode 10/100/1000 Ethernet (RJ45)
- RTC/EEPROM on IIC bus
- RS232 serial port via USB
- SPI interface to external Secure Digital (SD) card

